

# MATCO mfg

## Wheels & Brakes

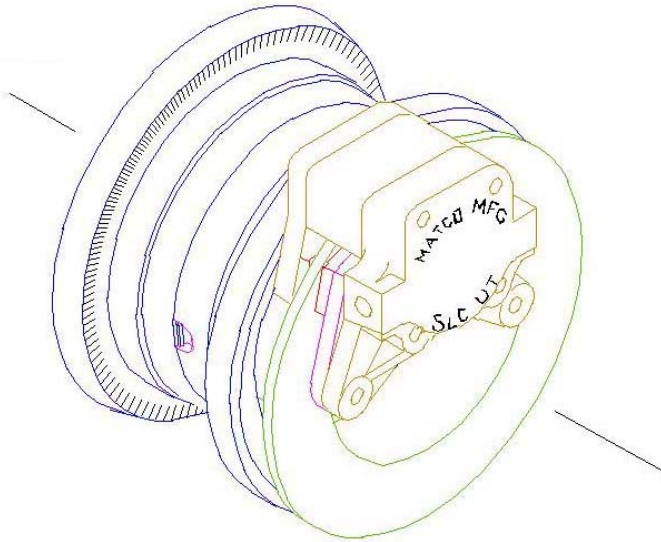

## **WE51 External Caliper 5" E - Series Wheel and Brake**

### Technical Service Bulletin

REV 2 6/02 SRT



### SUBJECTS

### PAGE

A. WE51 Wheel & Brake Assembly-----	3
B. WE51 Parts List -----	4
C. Assembly Diagram -----	5
D. Brake Lining Wear Limits-----	6
E. Brake Disc Inspection-----	7
F. Brake Lining Installation-----	8
G. Mounting the Tire & Tube-----	9
H. WE51 Wheel Assembly Instructions-----	10
I. Wheel Assembly Torque Values -----	12
J. Caliper Alignment-----	12
K. Bleeding the Brake System-----	13
L. Conditioning Procedures-----	14
M. Maximizing Brake Output -----	15
N. Lubricants-----	22
O. Technical Assistance-----	23

### DRAWINGS

Brake Assembly Drawing-----	5
Fig. 1 Brake Lining Wear Limits -----	6
Fig. 2 Minimum Disc Wear -----	8
Fig. 3 Tire Mounting Drawing-----	9
Fig. 4 Caliper Alignments-----	12
Dia. 1 Pedal Geometry-----	19
Dia. 2 Pedal Geometry -----	19
Dia. 3 Pedal Geometry -----	20
Dia. 4 Pivot Connect Geometry -----	20
Dia. 5 Heel Brake Geometry -----	21

## A. WE51 'E' SERIES FIVE-INCH WHEEL

### DIMENSIONS

The WE51 is an 'E' series five inch wheel with a width of 4.95 inches and 1.35 inch caliper spacing. 'E' series wheels utilize external calipers for easy maintenance. Bearing spacing is 2.80 inches and axle spacing is 1.55 inches. Total weight of the wheel and brake assembly is 6.1 pounds to include bearing and brake plate. Bearing axle diameter is 1.25 inches.

### FEATURES

The WE51 wheel is cast from 535.2 aluminum alloys for its superior strength, lightweight, and resistance to corrosion that is inherently found in magnesium wheels. The WE51 wheel uses a 1.25 inch tapered roller bearing, designed and rigorously tested for long life and resistance to bearing fatigue. The "E" series wheel features a single piston brake assembly with an external caliper for easy maintenance. Caliper removal is accomplished by removing two bolts giving easy access to the linings. Al-Ni-Brz bushings are used on 'E' series wheels to ensure smooth caliper travel. Machining of the wheel offers a precision cut, smooth clean surface for use with a variety of commercial tires. The WE51 can be fitted with the A1E bolt on axle, offering easy installation. A1E axles are made of black anodized 2024-T351 alloys with a bolthole diameter of 1.9 inches.

### PERFORMANCE

The WE51 is designed for the following performance standards:

Static Capacity	1,420 pound Load
Limit	4,260 pounds
Max Accelerate/Stop (Kinetic Energy)	118,121 foot-pounds
Torque Rating	1,990 in-lbs at 450psi

### COMPATABILITY

The WE51 can be substituted for the Cleveland 199-102 Kit, by adding a ¼ inch spacer on the brake side of the axle.

### TIRE & TUBE

Precision machining on the WE51 wheel allows for a variety of tires to include the Goodyear, McCreary, and Michelin. Any 500x5 tire and tube combination can be used. MATCO Mfg. recommends the Michelin Condor 500x5 6ply tire for its quality and performance.

#	PART NAME	QTY	MATCO PART #
1.	BOLT	2	MSCAN417A
2.	RIVET	2	MSC4-4
3.	WASHER	12	MSCAN960416L
4.	STATIONARY BRK SHOE	1	WHLSBS
5.	LINING	2	WHLM66-106
6.	BRASS RIVET	6	MSC4-6
7.	BRAKE PLATE 1.38 AXLE	1	WHLBP AE1.38
8.	SPACER	4	WHLBSPE5
9.	MOVABLE BRK SHOE 5/6"	1	WHLMBSE5
10.	PISTON 5/6" BRAKE	1	WHLPI-1
11.	O-RING BUNA N	1	MSC2-222
12.	PUCK HOUSING 5/6" BRK	1	WHLPH E-1
13.	FLEX LOCK NUT .25-28	3	MSCAN363-428
14.	ROLLER BEARING 1.25	2	WHLLM6700LA
15.	BEARING, RACE	2	WHLLM67010
16.	VALVE 1/2, W51L, 1.25 BRN	1	WHLW51/1.25
17.	BACK 1/2, W51L, 1.25 BRG	1	WHLNW511.25B
18.	BRAKE DISC, 5" BRAKE	1	WHLD164-017
19.	BUSHING	2	MSC1216-10
20.	BOLT	3	MSCAN4-22A
21.	DUST PLUG	1	MSC.234-X.50IL
22.	BRAKE BLEEDER VALVE	1	MSCF6446-007
23.	BRAKE BLEEDER SEAT	1	MSCBBS(A)
24.	LOCK NUT	2	MSC.25-28NY
25.	CAPLUG	1	MSC1X
26.	BOLT, SHOULDER	2	MSC.375X1.25SB

## C. BRAKE ASSEMBLY DRAWING

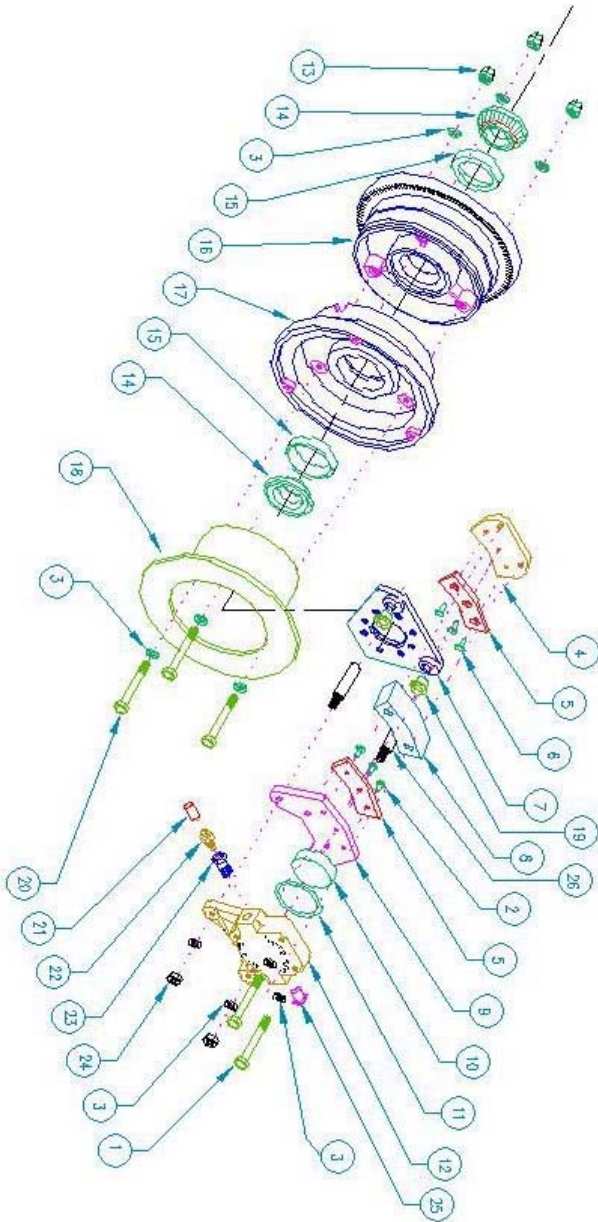

## D. BRAKE LINING WEAR LIMITS

To eliminate wear on brake linings beyond design limitation and reduce possible piston damage or fluid leakage, the following information is presented. The M66 series lining (as found on the WE51 series wheel) should be replaced when the thickness of the remaining wear material reaches 0.100 IN. (2.54mm) See Fig.1. The M66 lining has a visible wear notch located on the end of the lining that will tell the user when the pad is at the minimum material condition.

Fig. 1

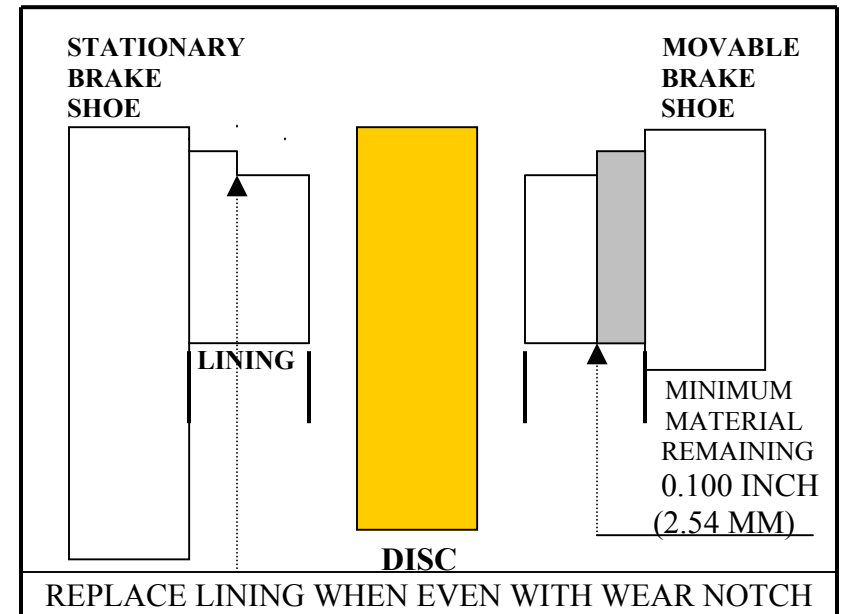

### SwiftLine Pad Replacement Program for the WE51

The *Swiftline* Pad Replacement program is designed to:

- Simplify pad replacement on MATCO mfg brakes
- Eliminate the need to rivet linings, saving maint. & tooling.
- Provide a 20 % discount on reline kits saving you money

**For more information on Swiftline call 801-486-7574**

## E. BRAKE DISC INSPECTION

The MATCO brake disc will give years of trouble free service under normal field conditions. Conditions such as unimproved fields, standing water, industrial pollution, or frequent use of the aircraft may require more frequent inspection of the brake system and disc in order to prolong the life of the brake linings.

The disc should be checked for wear (**Fig.2 Dim.“A”**) and for any grooves, deep scratches, excessive pitting or coning of the brake disc. Although coning is rarely a problem with the MATCO disc, if it should occur, coning beyond 0.015 inch (0.381mm) in either direction is cause for replacement.

Isolated grooves up to .030 inch (0.76mm) deep should not be cause for replacement. Any grooving of the disk however, will reduce the service life of the linings.

The WE51 disc is plated for rust prevention. Within a few landings, the plating will wear off where the linings rub against the disc. The remaining portion of the disc will remain plated and corrosion free for an extended period of time under normal use. Chrome plated discs are available from MATCO mfg. for those demanding increased corrosion protection and wear.

Rust in varying degrees may form on the exposed portion of the disc. If a powdered rust appears on this surface, one or two braking applications during taxiing should wipe the disc clear. Rust build up beyond this point, may require removal of the disc from the wheel to properly clean both surfaces. A wire brush followed by 220-grit sandpaper should restore the braking surface adequately. Do not remove plating in areas that are not contacted by the linings.

Fig. 2

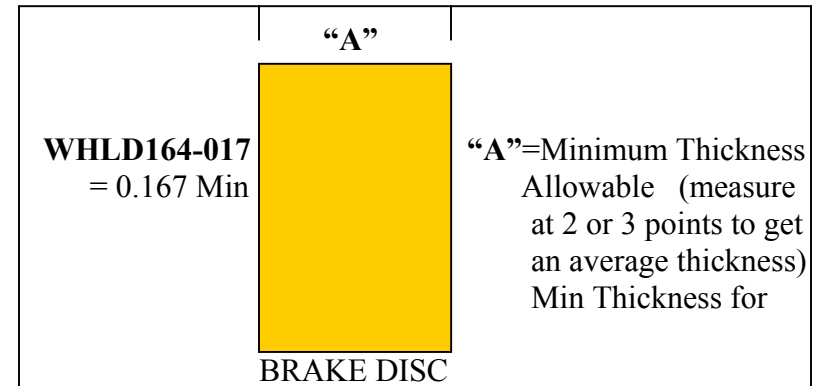

## F. BRAKE LINING INSTALLATION

The following instructions offer a guide for properly removing and replacing the WHLM66-106 brake linings.

1. Remove the caliper from the wheel by removing the two MSCAN4-10A bolts that hold it on.
2. Remove old linings by drilling the crimped side of the rivet (Do not use a punch & hammer). Using a #25 drill (0.1495 diameter), drill through rivet taking care to avoid damaging the rivet hole. After drilling crimped edge off rivets, lift old lining and remaining rivet pieces from the brake shoe.
3. Inspect the brake shoe for any bending or other damage that may have occurred during service. A shoe with more than 0.010 bend should be replaced. Inspect rivet holes to ensure that no damage has occurred during removal.
4. Using a brake relining tool (*MATCO recommends a Threaded Screw Action such as the W404 from Aircraft Tool SupplyCo.*) or pneumatic press, replace the lining using the brass rivets shown on the illustrated parts list.

## G. MOUNTING THE TIRE & TUBE

**NOTE:** MATCO wheels are balanced at the factory and stamped with a chevron. The chevron should always be placed adjacent to and directly across from the valve hole. Verify alignment before mounting the tire.

Care should be taken to avoid pinching the tube between the wheel halves when mounting the tire and tube. To avoid this, slightly inflate tube after placing it in the tire. Tire mounting soap may also help. A thin strip of cardboard or poster paper wrapped around the wheel between the mounting half and the tube will help in preventing the tube from being pinched during assembly if it is unusually tight. Another method is to use a strand of monofilament fishing line placed between the wheel and tube, and running the same direction as the axle. Move the line back and forth around the wheel as it is being tightened. When satisfied that the tube is clear simply pull it out. Note in **Fig. 3** that the stem nut rides in the slot between the wheel halves and is not designed to be tightened up against the inside of the wheel. It only acts as a guide in centering the tube.

**Fig. 3**

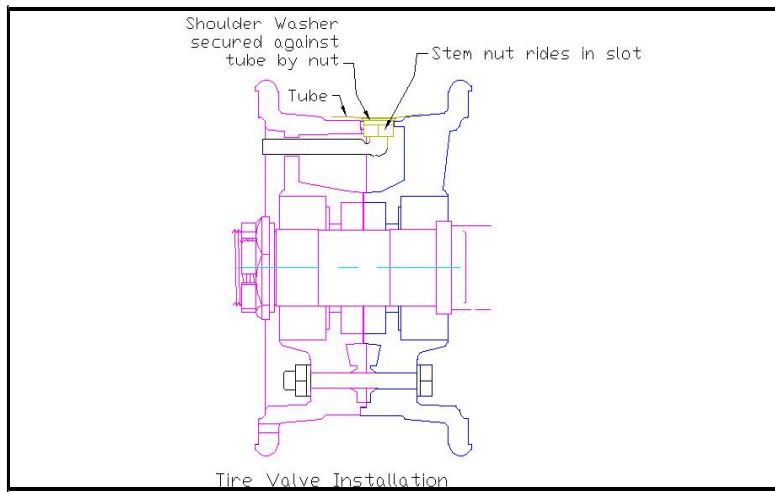

## ASSEMBLY INSTRUCTIONS FOR WE51:

1. The brake mounting plate (# 7 on assembly drawing) should be spaced from the bearing so that it aligns in the same plane and is parallel with the brake disc. (#18)
2. The tapered roller bearings are oiled from the factory to prevent rust, but are not greased. They should be cleaned, dried, and then packed with suitable grease. (*See Section "N" for suitable cleaners and lubricants*). Packing the bearings without removing the oil first, will dilute the grease, and allow it to run out past the seals causing early failure due to improper lubrication.

## **IMPORTANT NOTE: Axle Nut Torque**

Your MATCO Mfg. wheel is equipped with Timken tapered roller bearings with integrated grease seals on the bearing cone to ensure the longest possible life. Torque procedures for bearings with this type of seal are different than for bearings without them. A common torquing technique for bearings without seals is to tighten the axle nut until the wheel stops spinning freely then back off to the nearest locking feature. **THIS TECHNIQUE DOES NOT WORK ON BEARINGS WITH AN INTEGRATED SEAL.** The reason for the different technique is that the grease seal produces some drag and makes the wheel feel somewhat stiff when rotated. Reducing the axle nut torque until the wheel spins freely will allow the grease seal and the bearing cone to rotate improperly with the wheel. **THE CONE MUST NOT ROTATE RELATIVE TO THE AXLE.** The higher rolling drag is completely normal for this bearing and allows for longer bearing life since the seal will keep most contaminants out.

Timken specifications state that the two 1.25 inch tapered roller bearings used on the WE51 will produce 18-26 inch pounds of torque (*drag*) when properly installed. A light coating of grease on the seal will help reduce the drag on initial installation. The drag will also reduce after the bearings have been installed and the seal relaxes in the bore. It is important that the axle nut torque be sufficient to keep the seal from rotating with the wheel. The following technique will ensure the longest possible bearing life.

3. Tightened the axle nut until all play is out of the assembly. Rotate the wheel back and forth while tightening the nut to help seat the bearings. When all play is out and the wheel rotates freely, tighten to the next slot and insert cotter pin.
4. The rubber seal on the tapered roller bearing should remain stationary while the wheel rotates around it. If the seal is spinning on the axle, tighten the nut further until the seal stops spinning with the wheel. (*See Note Above*).
5. All o-rings in the brake and master cylinder assembly are Buna Nitrile and are NOT compatible with automotive glycol based brake fluids.

**NOTE** Use only red aircraft fluid Mil-H-5606 or other suitable petroleum or silicon-based fluids.

6. The ideal mounting position for the brake caliper is on the trailing side of the wheel with the inlet and bleeder valve in a vertical axis. However, the caliper may be mounted at any location as long as air can be properly bled from the system.
7. When using MATCO bolt on axles, they can be shimmed for toe-in or toe-out conditions, and spaced out from the wheel if necessary for the brake disk attachment screws to clear the landing gear leg. MATCO manufactures aluminum axles in black anodized 2024-T351 aluminum.

## I. WHEEL ASSY. TORQUE VALUES

DWG #	PART NUMBER	TORQUE VALUE (Inch Lbs)
13	MSCAN363-428	100 IN.Lbs.
24	MSC.25-28NYLOCK	100 IN. Lbs
26	MSC.375X1.25SB	100 IN. Lbs

## J. CALIPER ALIGNMENT

The brake caliper must be positioned properly when assembled on the axle. When using MATCO mfg. axle WHLA1E, the caliper alignment is assured because the bearing stops are machined into the axle. The WE51 wheel can also be mounted on a straight 1.25-inch axle. When using a straight axle, the required caliper spacing is shown in **Fig.4** below.

**Fig. 4**

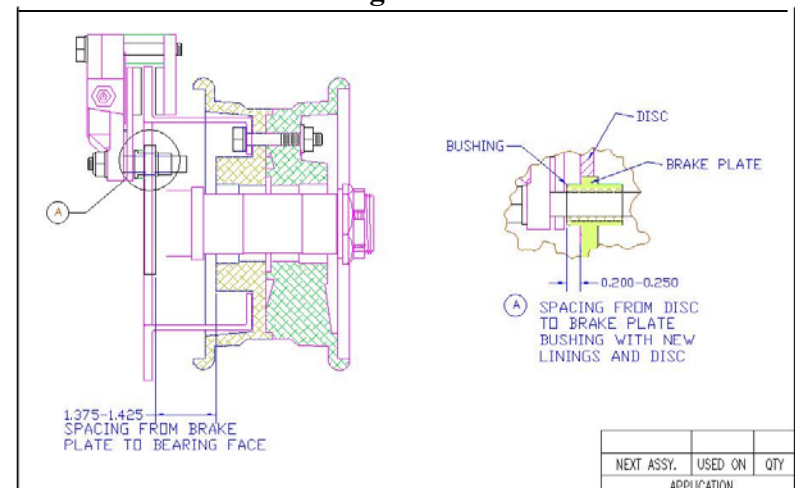

## K. BLEEDING THE BRAKE SYSTEM

1. Open the brake bleeder valve slightly (# 22 on the assembly drawing) to facilitate bleeding of air from the system.
2. Attach a tube from the nozzle of a squirt can (such as the MATCO squirt can part # MSCCHPSS) of brake fluid, to the top of the brake bleeder valve. Pump the handle until oil flows bubble free from service hose before attaching.
3. Make sure that the master cylinder shaft is fully extended to open up the internal bypass valve.
4. Inject brake fluid (Mil-H-5606) or equivalent, into the puck housing and continue injecting until the fluid travels through the system in to the master cylinder.
5. Air in the system will be pushed up and out in to the master cylinder ONLY IF the master cylinder or remote reservoir is at the highest point in the system, and there are no loops in the brake lines.
6. Fluid should be pushed through the system until it reaches approximately ¼ inch from the top of the master cylinder or remote reservoir
7. Close the brake bleeder valve, and remove the service hose.
8. If the brake system is free of air, the brake pedal should feel firm and not spongy. If not, repeat steps 1 through 7 until system is free of trapped air.
9. Fluid leakage from the top of the MCMC-5 master cylinder during operation indicates too high a fluid level.

**NOTE** The MCMC-5 is NOT approved for inverted flight.

## L. CONDITIONING PROCEDURES

**NOTE** It is important to condition the new linings after installation to obtain maximum service life and performance. The procedures below show when and how this should be done.

1. After the linings have been installed, apply brake pressure during high throttle static run-up. Note RPM at creep if any occurs.
2. Perform two or three taxi stops from approximately 30-35 mph to generate 300 – 400 degrees at brake pads. Allow brakes to cool for 10-15 minutes.
3. Repeat step one and note RPM at creep if any occurs. There should be a noticeable increase in holding torque.
4. If properly conditioned, the pads will have a uniform shiny appearance (*glaze*) on the surface.

**NOTE** forward movement of the aircraft while testing brakes, could be caused by skidding and not brake malfunction. Use caution when breaking heavy on aircraft with a tail-wheel as it could cause the tail to lift from the ground.

Conditioning removes high spots, and creates a layer of glazed material at the lining surface. Normal braking will produce enough heat to maintain glazing during the life of the lining. Glazing can be worn off during light use such as taxiing.

## M. MAXIMIZING BRAKE OUTPUT

### GETTING YOUR PEDAL GEOMETRY RIGHT

#### BRAKE SPECIFICATIONS

##### ENERGY RATING

All MATCO mfg. brakes have two specified ratings. The first is the energy rating which specifies the energy capacity of the brake. This value is used in selecting a brake that will be able to absorb the kinetic energy of the aircraft under the designers specified maximum energy condition (*generally maximum aircraft weight at a velocity above stall speed*). The energy rating is determined by the disc weight. Exceeding the energy capacity of a braking system leads to excessive disc temperatures. This can cause low friction coefficients and reduce brake torque and aircraft deceleration. Permanent damage to the disc can result in the form of warping or loss of corrosion protection.

##### BRAKE TORQUE

The second rating is for brake torque. The rated torque value is used to determine the deceleration and static torque for engine run-up that will be provided by the brake. A braking system using the same disc can have one energy rating and several torque ratings. This is possible by using different caliper configurations on the same disc. For example a braking system using a single caliper on a disc with an 189K ft-lb rating may have a torque rating of 1980 in-lb. The same braking system using two calipers would have the same energy rating of 189K ft-lb but would have a torque rating of 3960 in-lb. MATCO mfg. Offers its customers a wide range of caliper configurations and disc sizes to allow for meeting both energy and torque requirements for their aircraft.

### GETTING THE RATED TORQUE

The rated torque value assumes a nominally conditioned brake pad (*see pad conditioning procedures section 'L'*), rated pressure applied to the brake, free floating calipers, and pad contact on both sides of the disc. Brake pad conditioning allows a glaze to form on the pads and provides the highest friction coefficient and drag force. MATCO mfg. Brake torque ratings are based on 450 psi applied pressure. Pressures below this value will generate proportionally lower torque. Pressures above this value will provide higher torque although pressures above 600 psi generally cause caliper deflections that reduce the torque increase. The torque rating assumes that all caliper force is used to squeeze the brake pads against the disc. If the caliper does not float freely, it is possible that only one side of the disc surface may be contacted resulting in 50% loss of torque.

### GET THE PRESSURE RIGHT

Assuming the calipers are properly mounted so that the pads make contact on both sides of the disc (*both new and worn*) and are maintained so that the calipers float freely, the most common reason for under performance of the brakes is low pressure. MATCO mfg. Brakes need 450 psi to achieve their rated torque. Additional calipers can be added to get higher torque at a lower pressure but it is often more weight efficient to modify the hydraulic system pedal geometry to generate high pressures. Systems using hand or foot operated master cylinders require a minimum of 2.5 to 1 mechanical advantage when using master cylinder, MC, like the MC-4 or MC-5 which have .625 inch diameter pistons. (*Systems using MC-4 or MC-5 with intensifiers have .500-inch pistons and require a 1.6 to 1 mechanical advantage*). Mechanical advantage, MA, is the ratio of the force applied to the master cylinder shaft divided by the force applied by the hand or foot. **Dia.1** shows two examples of pedal geometry.

The first has an MA of 1 to 1 since the distance from the applied load to the pivot point is the same as the distance to the MC and is undesirable. The second shows a more favorable configuration that will easily provide the required pressure to the brakes with moderate toe force.

It is often necessary to keep the foot pedal shorter than that shown in **Dia.1**. An alternate geometry is shown in **Dia.2**. This design would utilize a fork arrangement on the MC connection to allow clearance of the MC body and then a short linkage to the MC connect point. A design common to many aircraft uses linkage as shown in **Dia.3**. This design also allows for a shorter brake pedal but has a major disadvantage. This linkage can be configured to have a proper MA in the start position (with the master cylinder fully extended). The MA varies with rotation however, as shown in **Fig.2** of **Dia.3**, a 15 degree rotation of the linkage reduces the MA at the start position from 1.5 to 1 down to only 1.12 to 1. In actual operation, this has the effect of causing a nearly constant brake torque even though increasing force is applied. For example, if the geometry is set for an initial MA 2.5 to 1. In the start position and the pilot applies pedal force, the MC will begin to stroke as pressure builds. As the rotation occurs, the MA decreases. If there is any air in the brake lines or if there are long brake line runs, hydraulic system expansion will occur as pressure increases requiring more MC stroke. If the pilot applies more pedal force, more MC stroke occurs, and the MA decreases further. Even though the pilot has now increased his pedal force, the force applied to the MC will be only marginally increased because more rotation will result and cause a further decrease in MA. A geometry like that in **Dia 2** will provide the same reduced pedal height and is not prone to the effect of rotation since the MC is essentially connected to the brake pedal pivot. **Dia.4** illustrates the benefit of pivot connect geometry during rotation. The MA remains virtually unchanged for expected rotation angles and results in a linear pressure increase with applied pedal force.

## HEEL BRAKES

A common means of providing pilots with differential braking ability without resorting to a more complicated geometry of toe brakes is to use heel brakes. The same design requirements exist for the MA of a system using heel brakes as for toe brakes. It is not uncommon to see MC's configured to allow the pilot to apply heel force directly to the MC by means of a pad or button connected on the end of the shaft. This configuration is shown in **Fig.1** of **Dia.5**. The MA of this system is 1 to 1 and produces very low pressure for reasonable heel force. Perhaps a larger concern however is the potential for causing damage to the MC. The MC is designed to accept loads applied along the length of the shaft. Loads applied off axis or perpendicular to the shaft cause bending moments in the MC shaft that it is not designed for. Damage to the MC end gland, or bending of the MC shaft may result if the off axis brakes is shown in **Fig.2** of **Dia.5**. This system uses a short linkage connected to the MC that provides the 2.5 to 1 MA while insuring that loads will be applied along the length of the MC and prevent any damage during actuation.

## CONCLUSION

Like any system on an aircraft, the hydraulic system has many engineering options for providing the necessary requirements. The systems common on light aircraft must be engineered to provide adequate pressure to the brakes to achieve the rated torque. MATCO mfg. Brakes require 450 psi to achieve the rated torque. The pedal geometry whether hand, toe, or heel operated, requires a mechanical advantage of at least 2.5 to 1. This allows the pilot to easily generate the required 450-psi with moderate applied force. Pivot connected geometry provides the best means of accomplishing this requirement without the problem of rotational effect that reduces mechanical advantage.

### PEDAL GEOMETRY / POOR & MINIMUM

Dia. 1 Figures 1 & 2

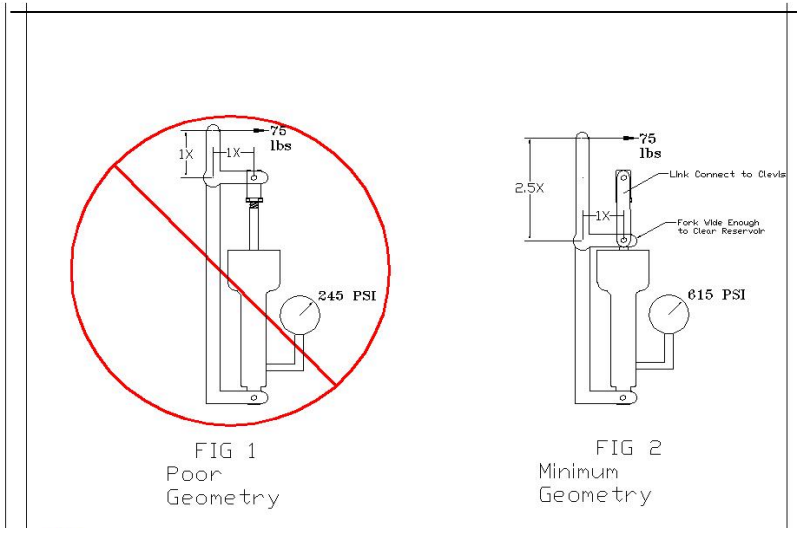

### PEDAL GEOMETRY / MECHANICAL ADVANTAGE

Dia. 3 Figures 1 & 2

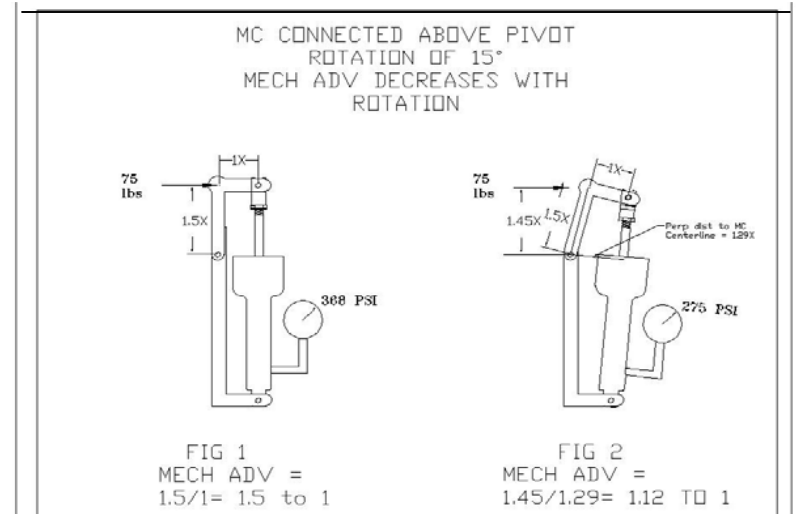

### PEDAL GEOMETRY / POOR & MINIMUM

Dia. 2 Figures 1 & 2

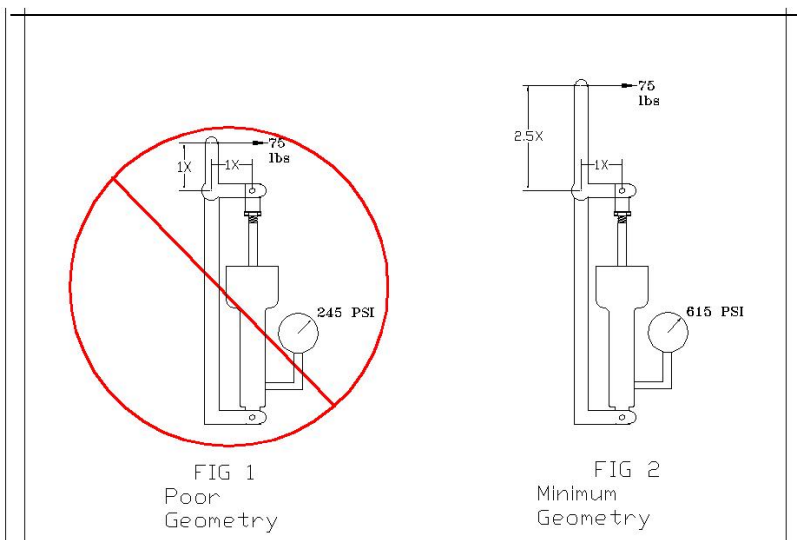

### PEDAL GEOMETRY / PIVOT CONNECT

Dia. 4 Figures 1 & 2

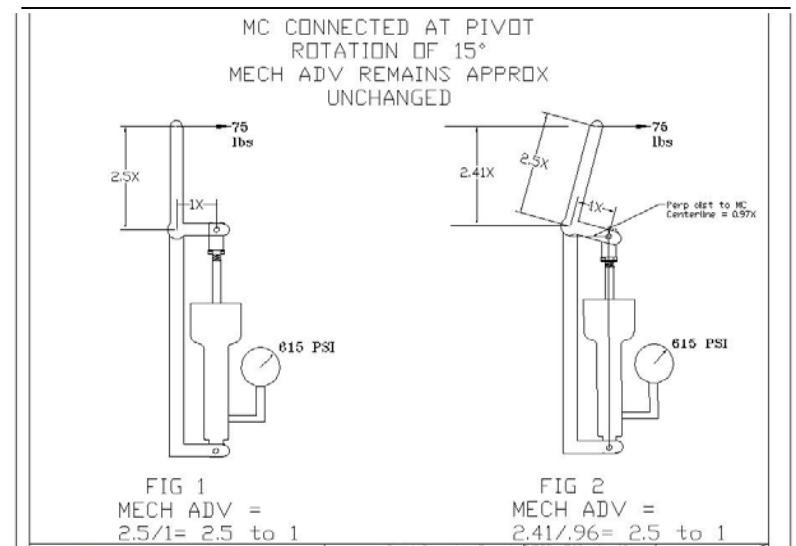

## PEDAL GEOMETRY / HEEL BRAKES

Dia. 5 Figures 1 & 2

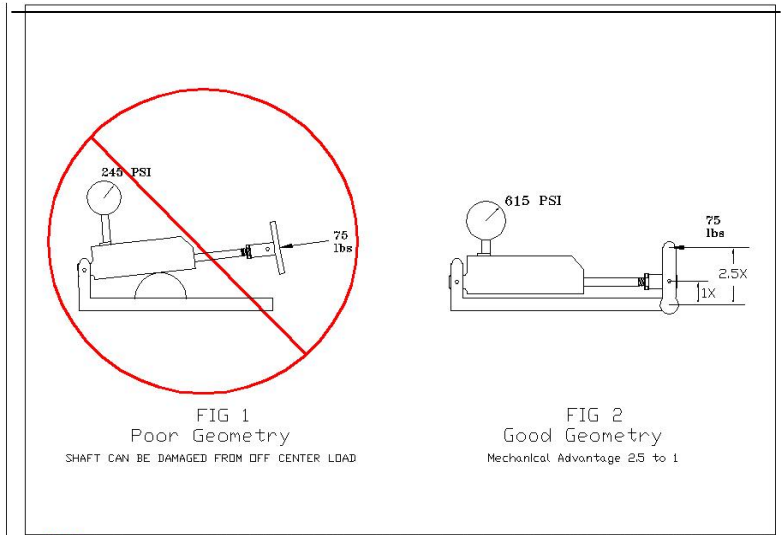

## ELASTOMERIC COMPOUND LUBRICANTS

HYDRAULICS: MIL-H-5606 / MIL-H-83282  
Or equivalent (Red Oils)

## PETROLEUM LUBRICANTS

WHEEL BEARINGS: MIL-G-81322  
MOBIL 28  
AEROSHELL 22  
Or equivalent lubricants

AMPHIBIOUS: HCF Grease P/N 605  
BG Products, Wichita, KS.

WHEEL NUTS / BOLTS: MIL-T-5544 Antiseize  
or equivalent

## THREAD SEALANT

TAPERED PIPE THREADS: Loctite 567, or equivalent  
Petroleum product.

## O. TECHNICAL ASSISTANCE

For technical information, product matching,  
and helpful hints, see our website at:

[www.matcomfg.com](http://www.matcomfg.com)

E-mail our Technical Service Manager  
for specific information at:

[tech@matcomfg.com](mailto:tech@matcomfg.com)

## TECHNICAL ASSISTANCE

To speak with someone in person about specific  
products or to find answers to technical questions,  
please contact us at our

TECHNICAL HOTLINE

**801-486-7574**

OR FAX US AT 801-486-7581

## NOTES

