

This Assembly uses  
Mil-H-5606 Hydraulic  
Fluid

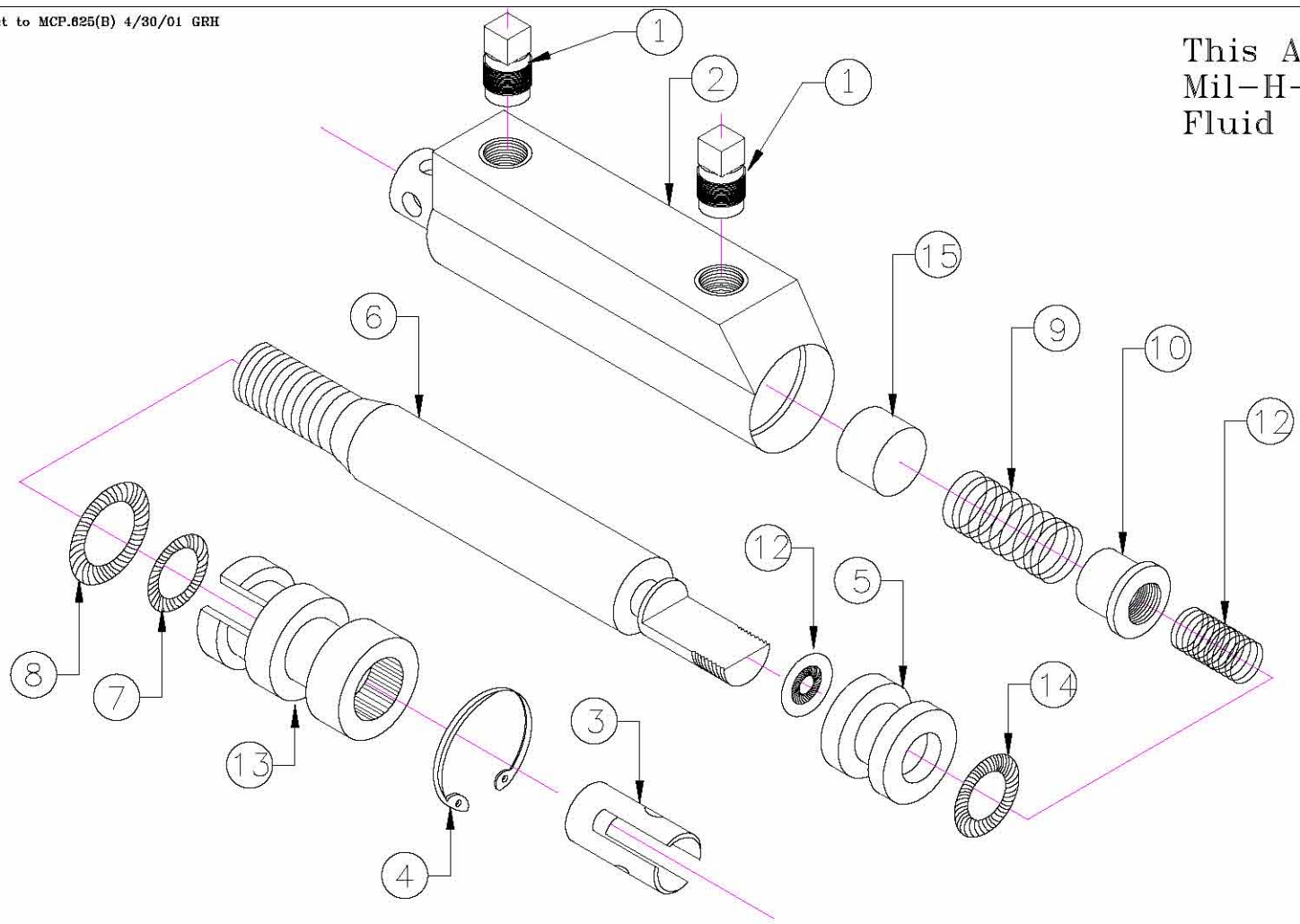

NO.	PART NAME	INVENTORY NO.	REQ'D	NO.	PART NAME	INVENTORY NO.	REQ'D
1	THREADED PLUG	P-18	2	11	VALVE SPRING	C0300-026-0440M	1
2	MC-4 HOUSING	MC4H(A)	1	12	STATO SEAL	600-0101-10	1
3	CLEVIS, SHORT	MC-17S	1	13	END GLAND	MC4-2	1
4	SNAP RING MC-4	3000-X68	1	14	O-RING BUNA N	2-111	1
5	PISTON	MCP.625(B)	1	15	PEDESTAL, MC-4A	MC-18	1
6	SHAFT, MC-4G	MC4G-1	1				1
7	O-RING BUNA N	2-012	1				
8	O-RING BUNA N	2-112	1				
9	SPRING	C0480-055-2500M	1				
10	SPRING GUIDE	MC-16	1				